

US Series Energy Storage System

Quick Installation Guide

Issue: V1.9a

Date: 2025-04-18

FOXESS CO., LTD.



Notice

1. The information in this document may not be modified, copied or reproduced, in whole or in part, without the prior written permission of FOXESS CO., LTD. All information in this document is provided to the best of our knowledge and efforts, but does not constitute a warranty of any kind, express or implied. You can download quick guide and user manual by scanning the QR code.



2. Only certified electricians are allowed to operate the device. Operation personnel must wear proper personal protective equipment (PPE).

3. Before installing the device, check that the package contents are intact and complete against the packing list. If any damage is found or any component is missing, contact your dealer.

4. The device damage caused by the violation of instructions in this document is not covered under warranty.

5. The cable colors involved in this document are for reference only. Select cables in accordance with local cable specifications.

1 Packing List

1.1 Hybrid Inverter Package Box

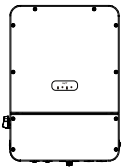

A



B

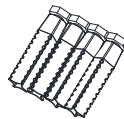

C



D



E



F

OBJ	QTY	DESC	OBJ	QTY	DESC
A	1	Inverter	D	1	Set Screw
B	1	Bracket	E	1	Quick Installation Guide
C	4	Expansion Bolt M8*60	F	1	Cable Sticker

1.2 FOX Hub G2 Package Box



A

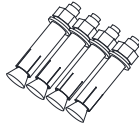

B



C

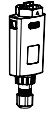

D

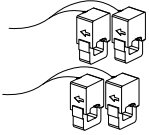

E



F



G

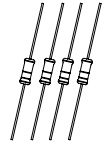

H



I

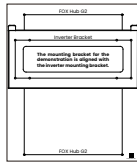

J



K

OBJ	QTY	DESC	OBJ	QTY	DESC
A	1	FOX Hub G2	G	1	E-STOP
B	4	Sleeve Expansion Bolt M8*60	H	4	120Ω Terminating Resistor
C	4	Waterproof Gasket	I	3	Label
D	1	Smart WiLAN	J	1	Installation Paperboard
E	4	250A Current Transformer	K	1	Pry bar for relays
F	1	100A Current Transformer			

1.3 Battery Package Box

For CM:



A

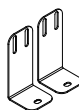

B



C



D



E

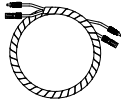

F



G



H



I



J



K



L



M

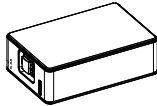

N

OBJ	QTY	DESC	OBJ	QTY	DESC
A	6	Set Screw	H	4	Expansion Tube & Expansion Screw
B	2	Fixing Bracket	I	1	Waterproof Cover
C	4	Footstand	J	1	RJ45
D	1	Communication Cable (BMS-inverter) (9.8ft)	K	1	Junction Box
E	1	Grounding Cable (9.8ft)	L	2	Plug
F	1	DC Output Cable (9.8ft)	M	1	Cable Gland
G	1	Quick Installation Guide	N	1	CM

For CS :



A



B

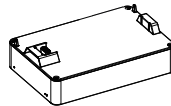

C

OBJ	QTY	DESC	OBJ	QTY	DESC
A	2	Set Screw	C	1	CS
B	1	Quick Installation Guide			

NOTE: This manual takes the ECS4000 series battery as an example. Always refer to the actual product and its quick install guide.



Safety Goggles



Steel Toe Boots



Dust Mask



Helmet



Insulating Gloves



Phillips-Head Screwdriver



Flat-Head Screwdriver



Wire Stripper



Electric Drill



Adjustable Wrench



Hex Wrench Set



Hole Punch

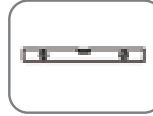

Level



Tape



Sleeve



Multimeter

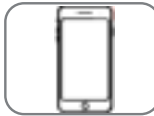

Phone

**DANGER:**

Special care must be taken to protect personal safety.

PPE must be worn during transfer and installation.

**WARNING:**

Please use proper protective measures, such as foam or protective cloth, keep the inverter and FOX Hub G2 well protected from hard objects that may damage their exterior appearance or body during handling and installation.

3 Installation Steps

3.1 Installation Environment

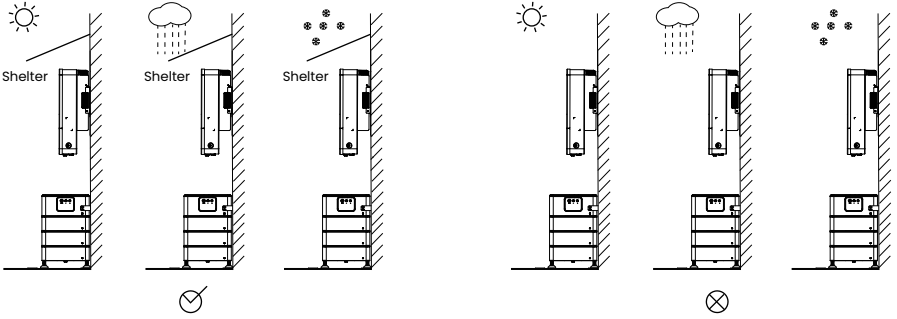

3.2 System Installation Space

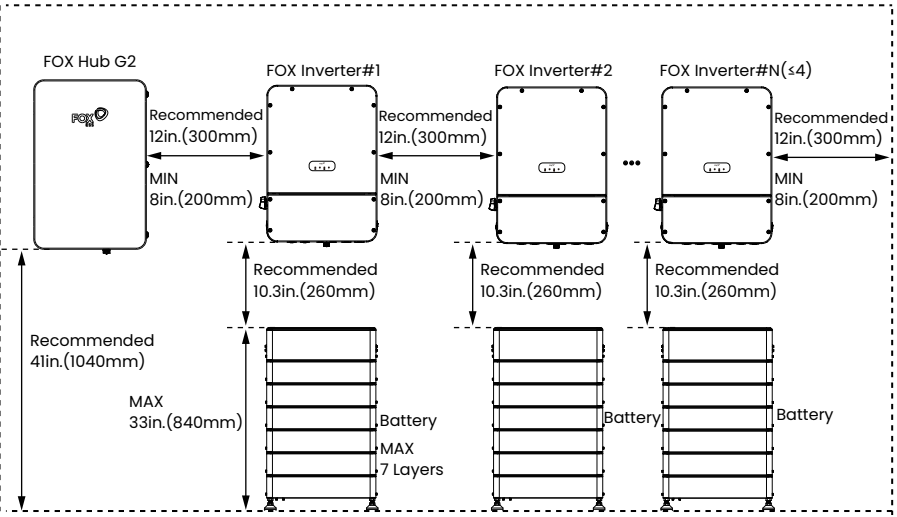

3.3 Inverter Installation

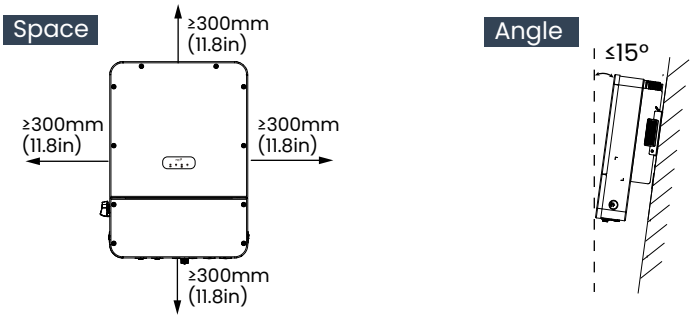

Steps

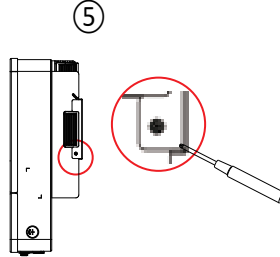
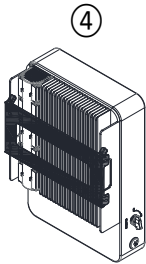
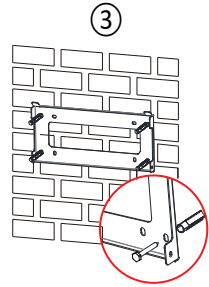
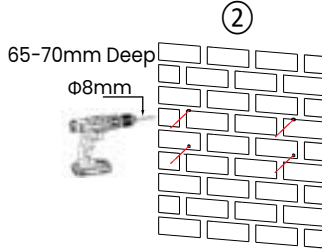
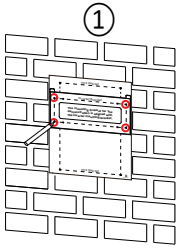

3.4 FOX Hub G2 Installation

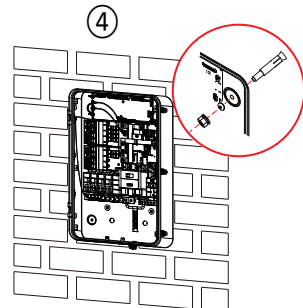
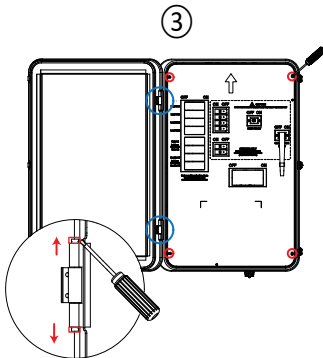
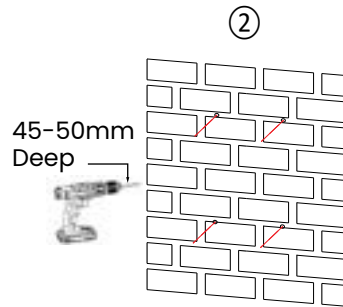
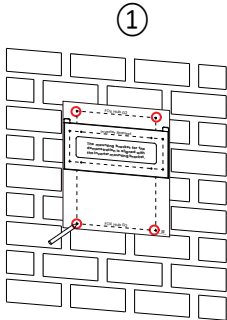

Suggestion: the height difference between the highest installation holes of the FOX Hub G2 and the highest installation holes of the inverter bracket is 3.5in. (89.3mm).

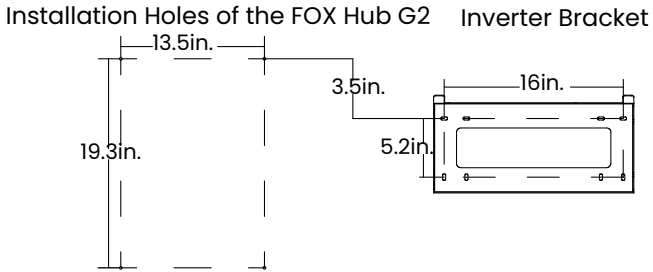

3.5 Battery Installation

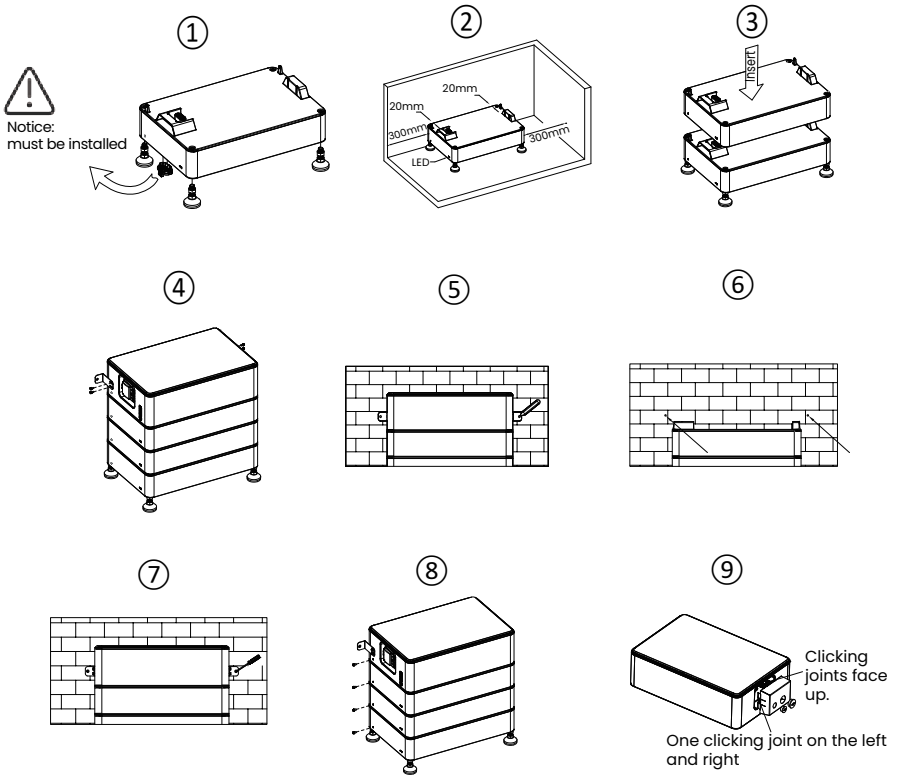

NOTE: This manual takes the ECS4000 series battery as an example. Always refer to the actual product and its quick install guide.

NOTE:

Parallel operation requires inverters of identical models, and batteries matching in both model and capacity.

4.1 Whole-home Backup

NOTE:

In **Canada**, the FOX Hub G2 cannot function as a service panel, so add a **Main Panel** as a service panel between the **FOX Hub G2** and **utility meter**.

Whole-home Backup (DC Couple)

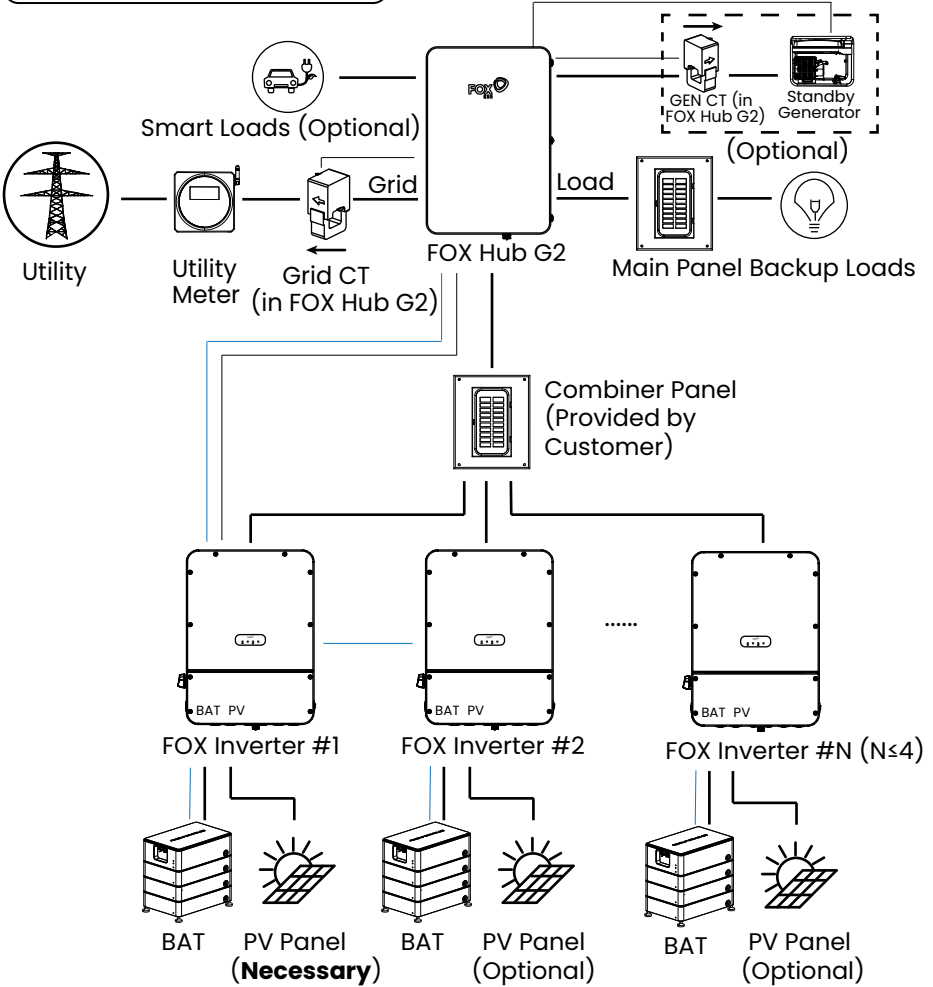
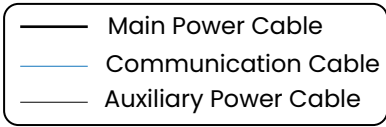

Whole-home Backup (AC Couple)

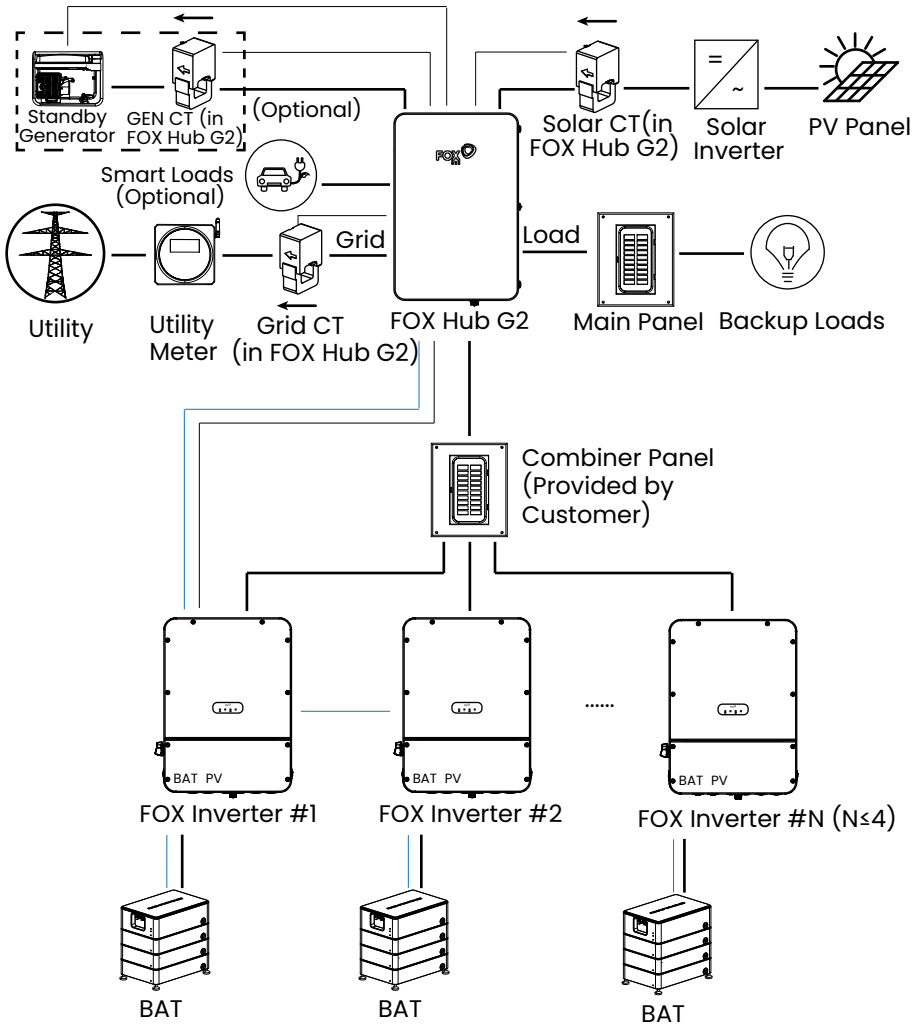
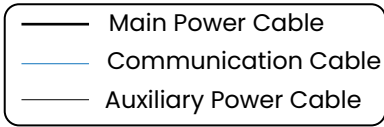

4.2 Partial-home Backup

NOTE:

 In **Canada**, the FOX Hub G2 cannot function as a service panel. Utilize diagrams showing the FOX Hub G2 in non-service panel modes.

Partial-home Backup (DC Couple) (FOX Hub G2 as Service Panel)

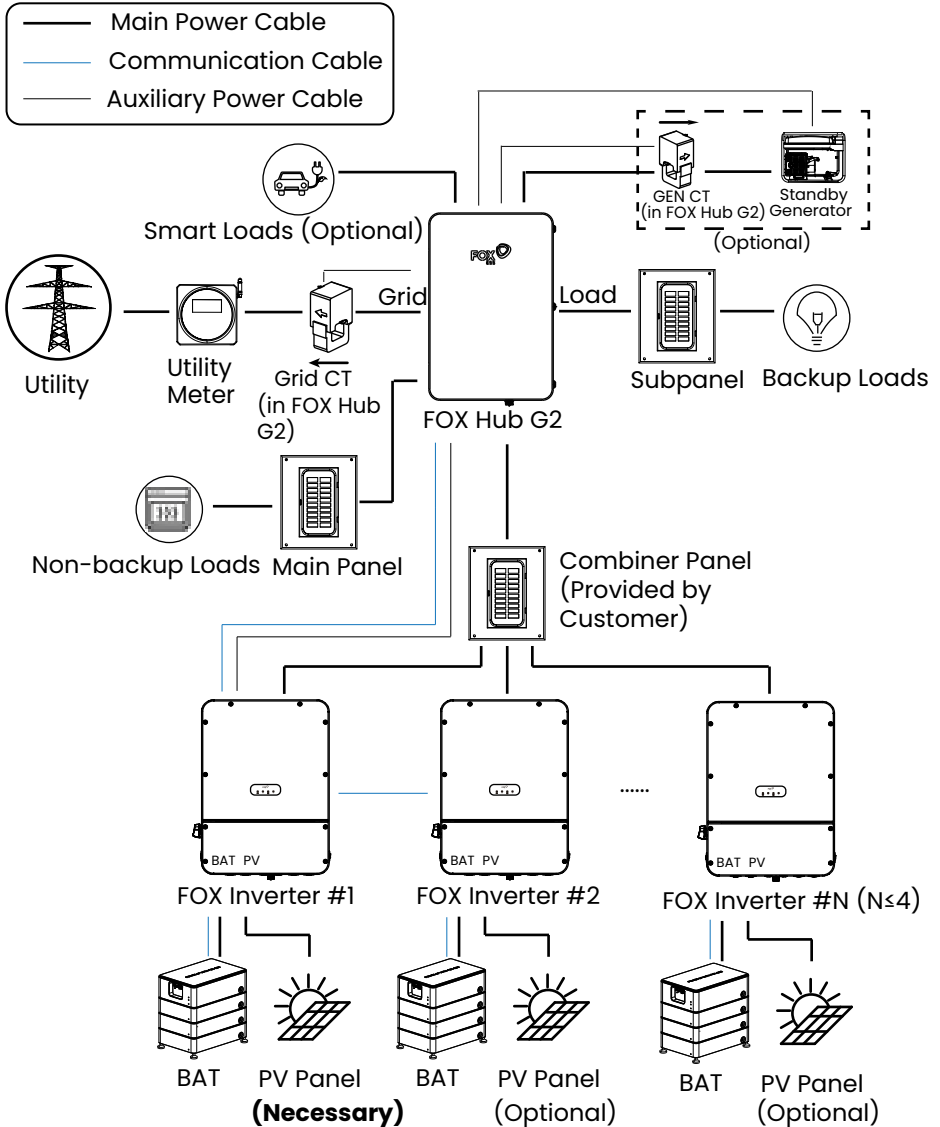

Partial-home Backup (DC Couple) (FOX Hub G2 not as Service Panel)

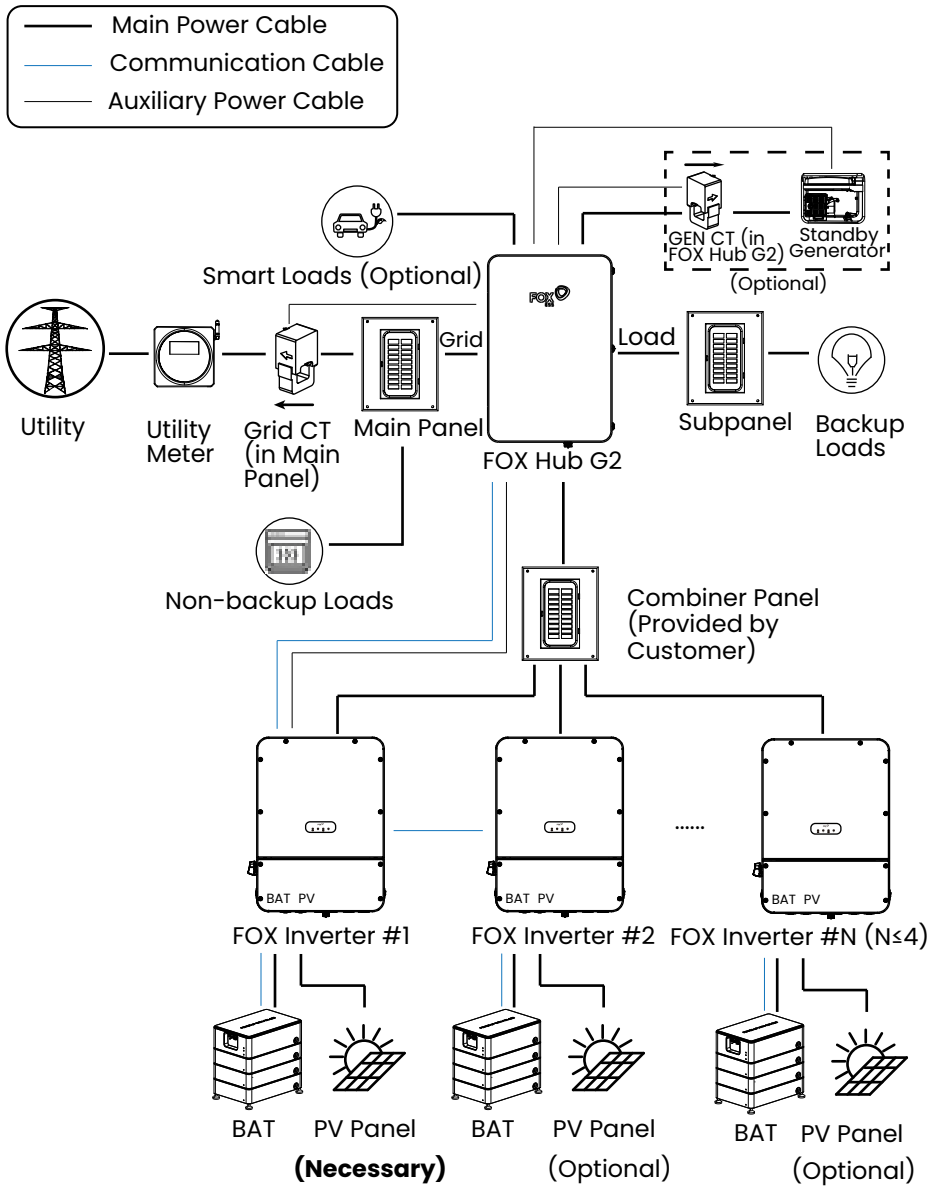

Partial-home Backup (AC Couple) (FOX Hub G2 as Service Panel)

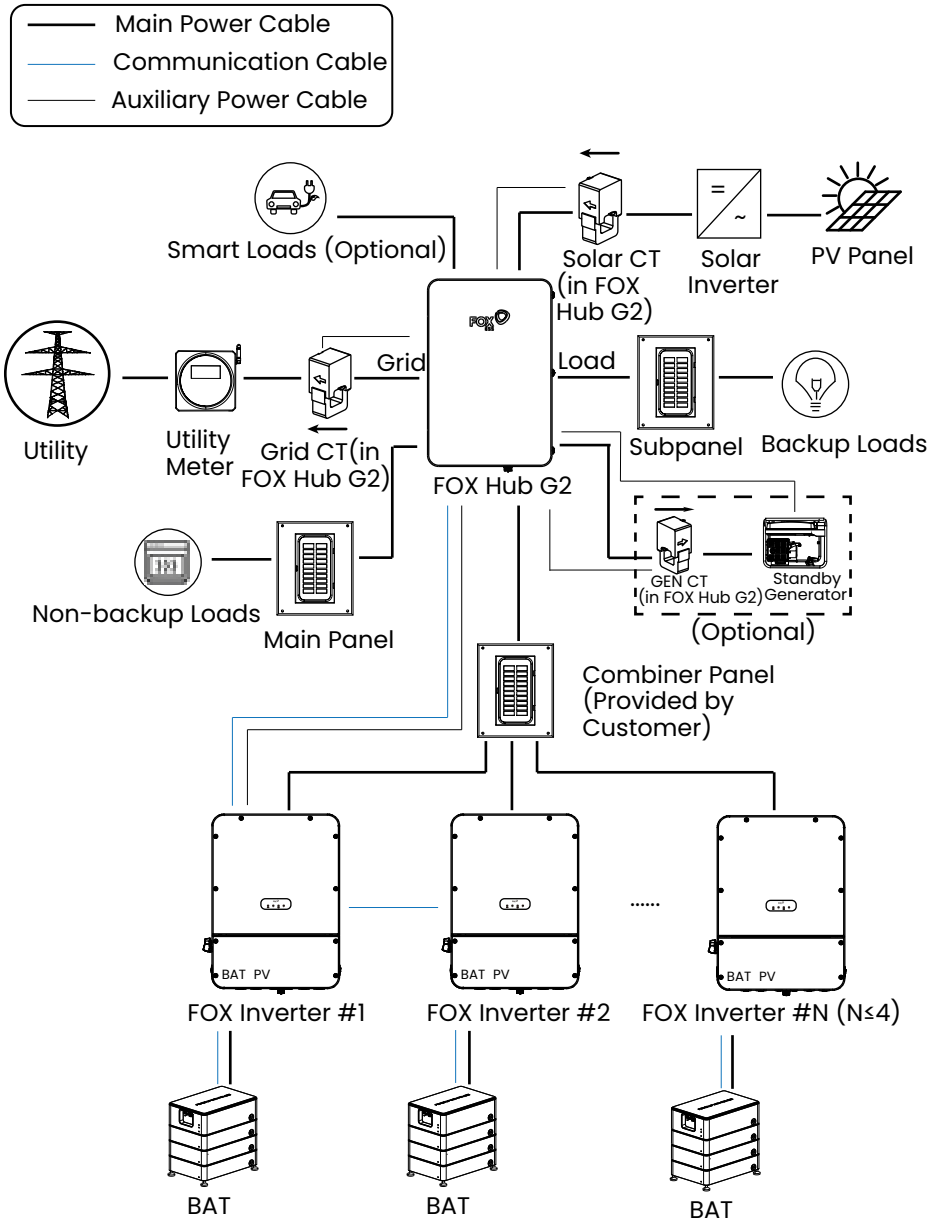

Partial-home Backup (AC Couple) (FOX Hub G2 not as Service Panel)

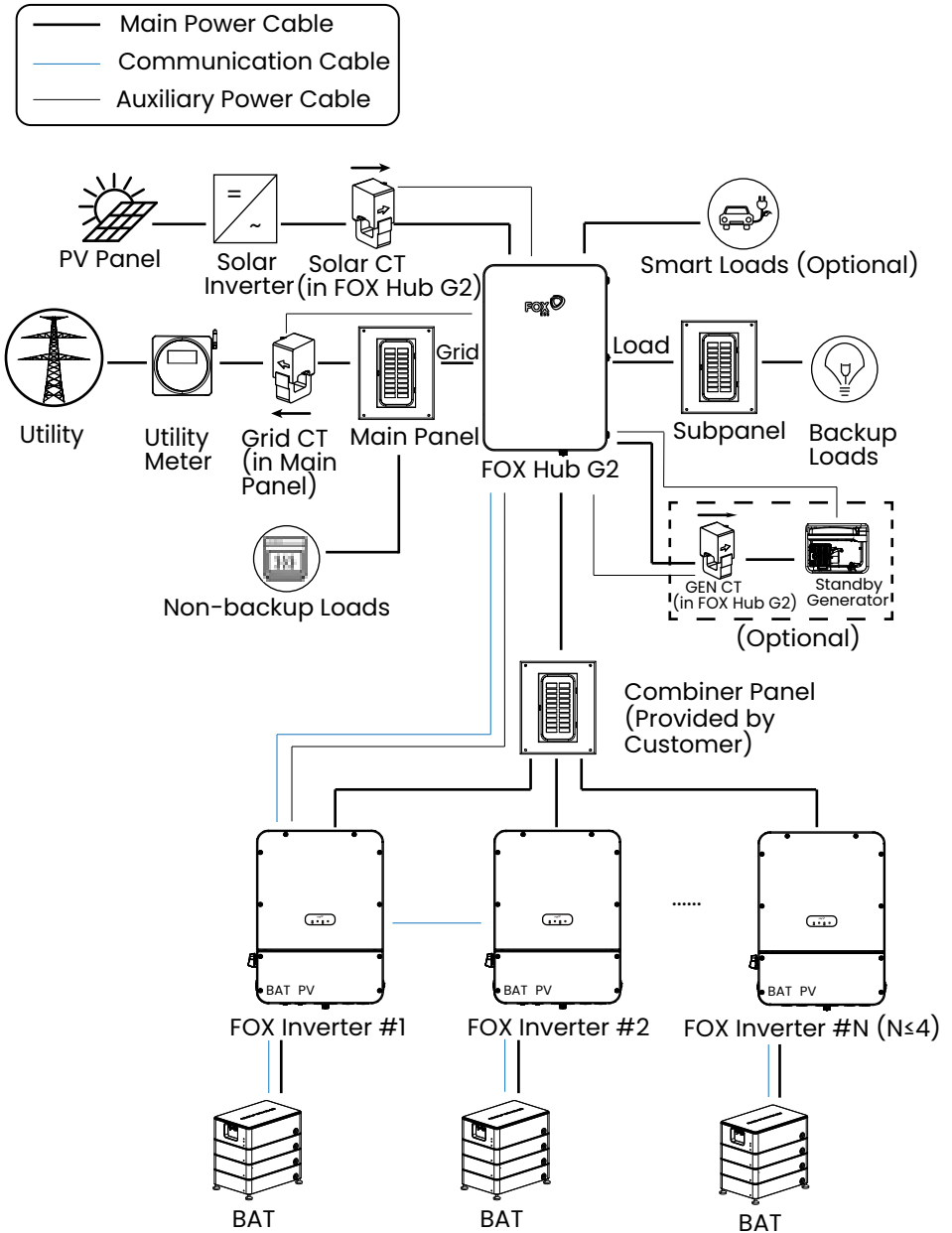

5 System Wiring Steps

5.1 FOX Hub G2 Overview

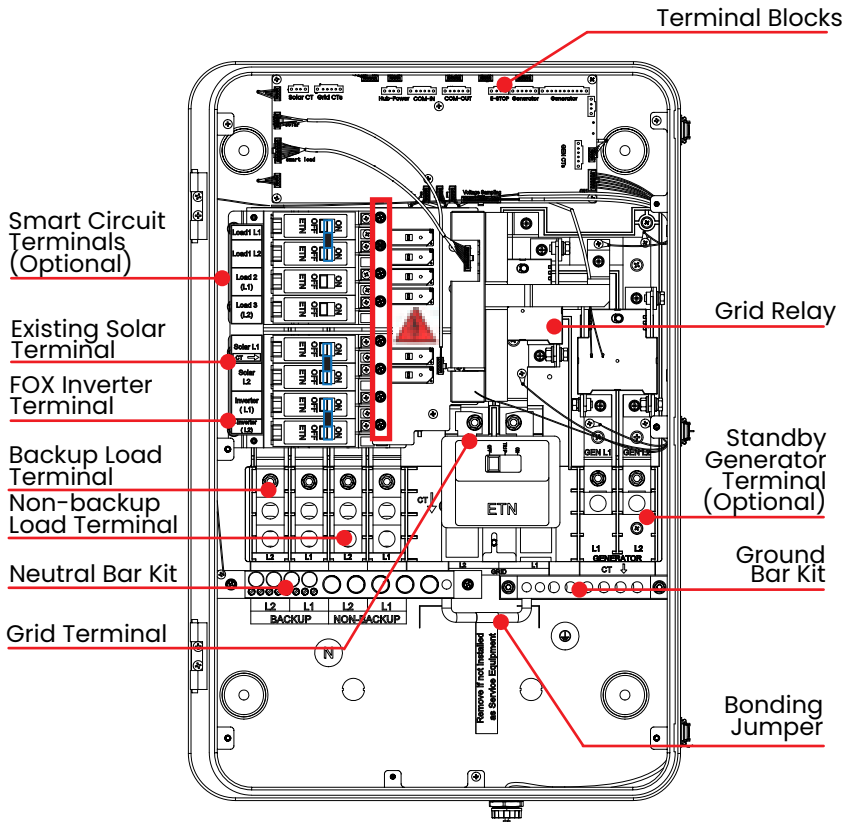

DANGER:



The framed screws are live. There is risk of electric shock. Disconnect units before servicing.

5.2 Is the FOX Hub G2 Installed as Service Panel?

① When the FOX Hub G2 is used as the service panel,

a. main breaker and line side barriers (Eaton TICS300C) need to be installed;

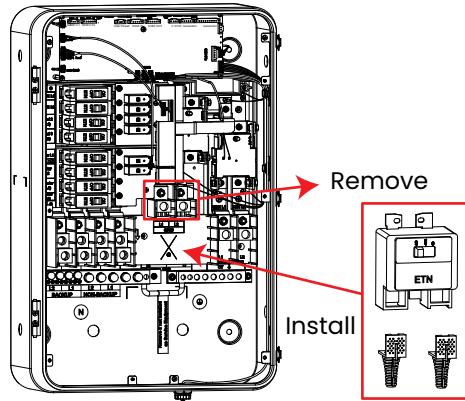

b. labels of "SERVICE DISCONNECT" and "SUITABLE FOR USE AS SERVICE EQUIPMENT ONLY IN USA WHEN EQUIPPED WITH MAIN BREAKER" shall be applied to the black protection cover.

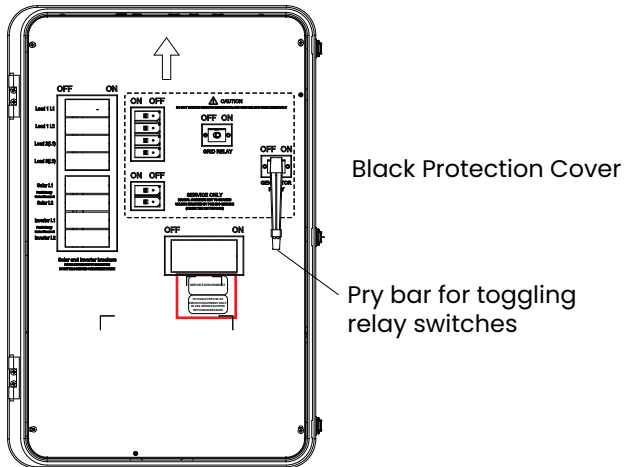

Warning:



- ① Do not switch on both generator and grid relays simultaneously.
- ② Before toggling the two relays, please disconnect the AC breaker and shut down the PowerQ.

- ② When the FOX Hub G2 is not used as the service panel, bonding jumper needs to be removed.

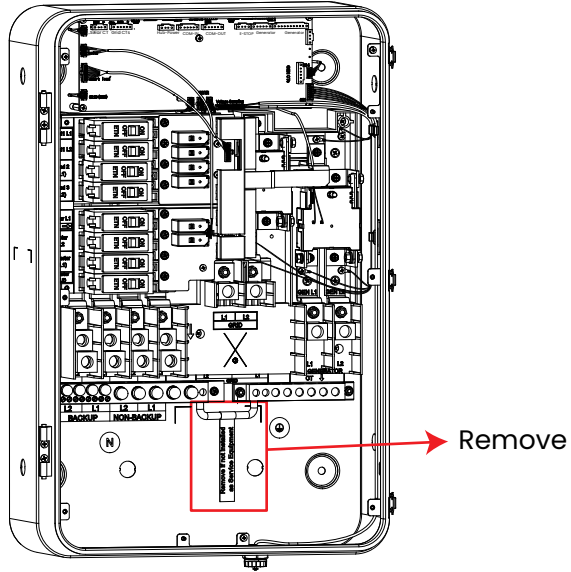

③ Recommended Breaker Models

Circuit	Compatible Breaker
Smart Circuit (Back-fed breaker) (Optional)	CH230, CH235, CH240, CH245, CH250, CH260, CH270, CH280, CHF230, CHF235, CHF240, CHF245, CHF250, BR230, BR240, BR250, BR260, BR270, BR280, BR290, BRH230, BRH240, BRH 250, BRH260, BRH270, BRH 280, BRH 290, BR170, BR160, BR150, BR140, BR130, BRH170, BRH160, BRH150, BRH140, BRH130
Existing Solar (Branch breaker)	CH230, CH235, CH240, CH245, CH250, CH260, CH270, CH280, CHF230, CHF235, CHF240, CHF245, CHF250, BR230, BR240, BR250, BR260, BR270, BR280, BR290, BRH230, BRH240, BRH 250, BRH260, BRH270, BRH 280, BRH 290,
FOX Inverter (Branch breaker)	CH230, CH235, CH240, CH245, CH250, CH260, CH270, CH280, CHF230, CHF235, CHF240, CHF245, CHF250, BR230, BR240, BR250, BR260, BR270, BR280, BR290, BRH230, BRH240, BRH 250, BRH260, BRH270, BRH 280, BRH 290,
Grid (Main breaker) (Optional)	CSR2100, CSR2125N, CSR2150N, CSR2175N, CSR2200N, BW2100, BW2125, BW2150, BW2175, BW2200, BWH2100N, BWH2125N, BWH2150N, BWH2175N, BWH2200N

④ NEC 2023 Requirement of Current rating:

1. 705.12 (b)(1): bus bar rating shall not less than main breaker rating + breaker of other power source (125% of power source output).

2. 705.12 (b)(2): only two power sources: primary power source is located on opposite end of other power source. bus bar rating x 120% shall not less than main breaker rating + breaker of another power source (125% of power source output). Need following marking:

POWER SOURCE OUTPUT CONNECTION. DO NOT RELOCATE THIS OVERCURRENT DEVICE.

3. 705.12 (b)(3): the sum of overcurrent protection device excluding main breaker shall not more than bus bar rating. And main breaker shall not more than bus bar rating. Need following marking:

WARNING:

THIS EQUIPMENT FED BY MULTIPLE SOURCES. TOTAL RATING OF ALL OVERCURRENT DEVICES EXCLUDING MAIN SUPPLY OVERCURRENT DEVICE SHALL NOT EXCEED AMPACITY OF BUSBAR.

5.3 FOX Hub G2 Power Cable Wiring

5.3.1 Size of Conduit and Cable Gland

FOX Hub G2			
Cable Marker	Max. Cable Diameter	Conduit	Gland
L1	4/0 AWG	EMT 2"	M75 or adapts to 2" EMT conduit
L2	4/0 AWG		
N	4/0 AWG		
PE	4 AWG		

Inverter			
Cable Marker	Max. Cable Diameter	Conduit	Gland
L1	6 AWG	EMT 3/4"	M32
L2	6 AWG		
N	6 AWG		
PE	6 AWG		

5.3.2 The FOX Inverter Connections to the FOX Hub G2 (One FOX Inverter)

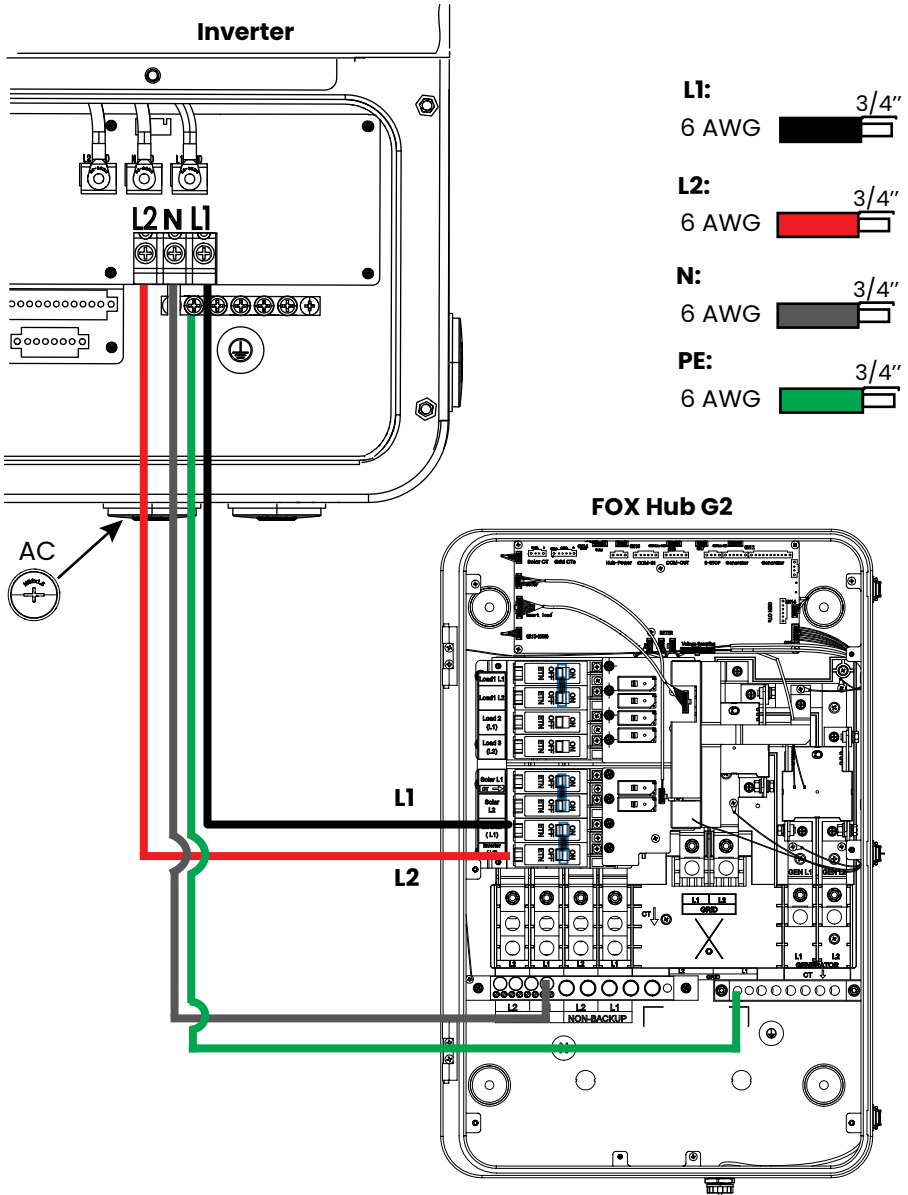

5.3.3 The FOX Inverter Connections to the FOX Hub G2 (2 to 4 FOX Inverters)

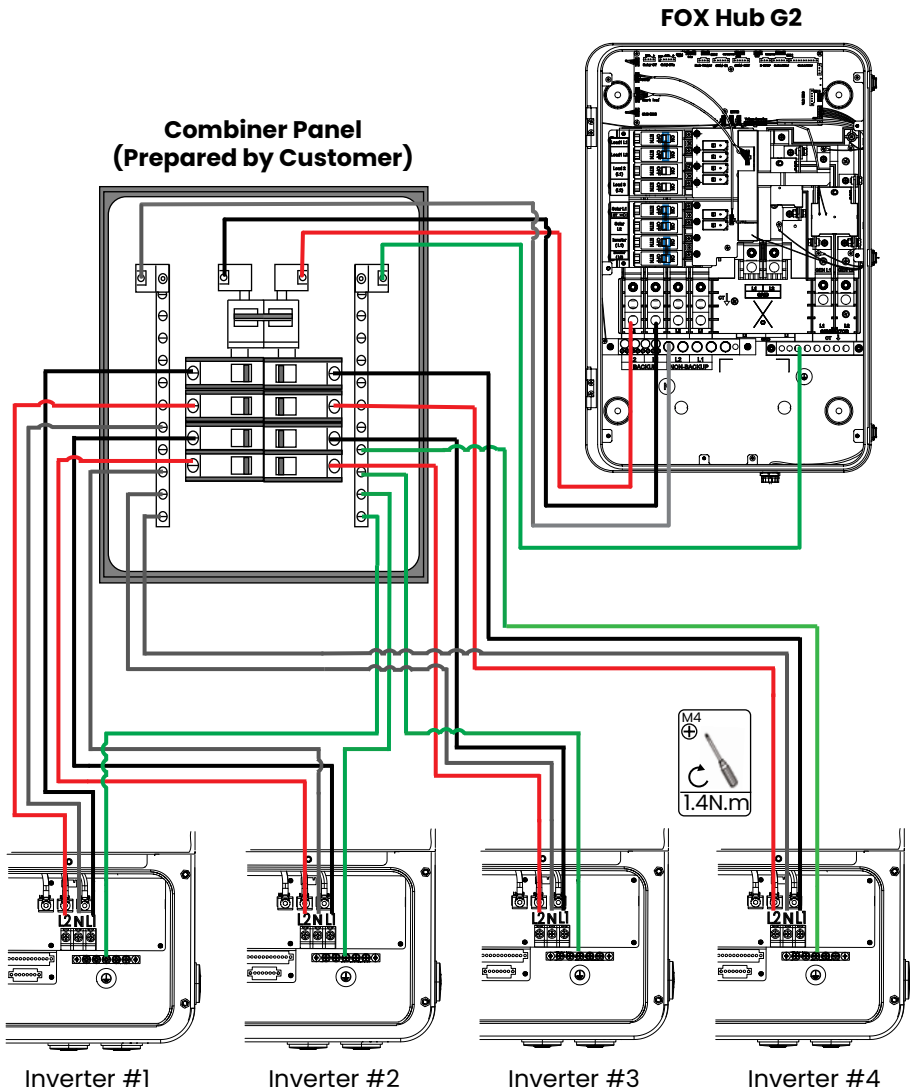

No. of Parallel Inverters	Minimum Wire Gauge (Combiner Panel-FOX Hub G2)
2 Inverters	2 AWG
3 Inverters	2/0 AWG
4 Inverters	4/0 AWG

No. of Parellel Inverters	Wire Gauge (Combiner Panel—Inverter)
2 Inverters	6 AWG
3 Inverters	6 AWG
4 Inverters	6 AWG

5.3.4 Backup Loads Connections to the FOX Hub G2

- L1:**
6 AWG - 250 kcmil  3/4"
- L2:**
6 AWG - 250 kcmil  3/4"
- N:**
6 AWG - 250 kcmil  3/4"
- PE:**
6 AWG - 2/0 AWG  3/4"

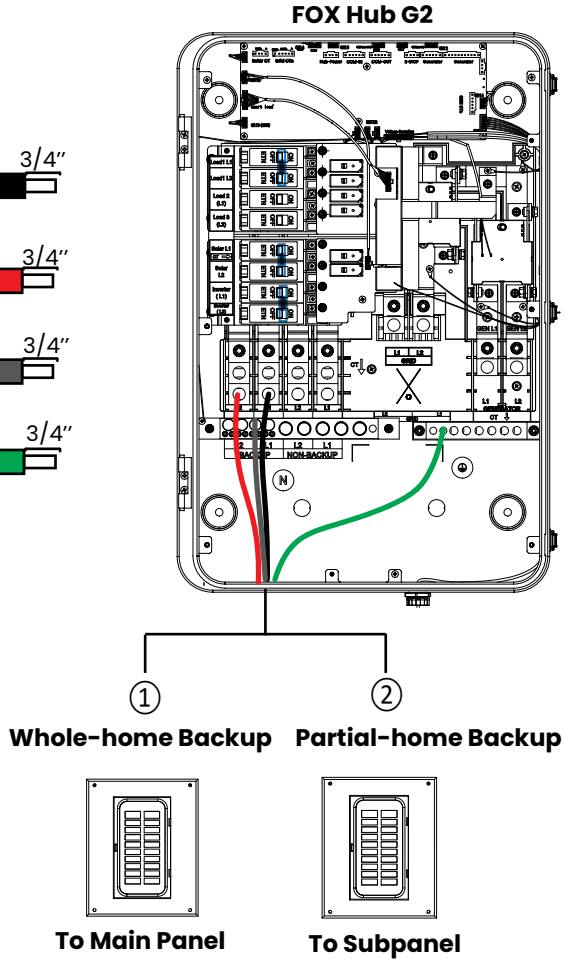

5.3.5 Non-backup Loads Connections to the FOX Hub G2

- L1:**
6 AWG - 250 kcmil 
- L2:**
6 AWG - 250 kcmil 
- N:**
6 AWG - 250 kcmil 
- PE:**
6 AWG - 2/0 AWG 

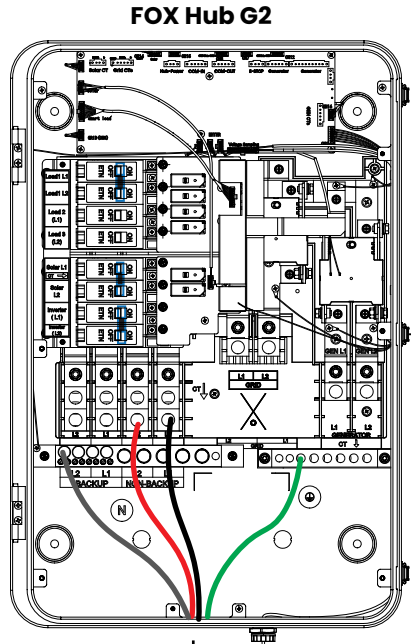

Partial-home Backup

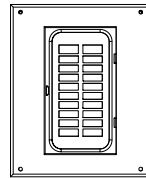

To Main Panel

5.3.6 The Grid AC Power Connections to the FOX Hub G2

L1:
6 AWG - 4/0 AWG 

L2:
6 AWG - 4/0 AWG 

N:
6 AWG - 4/0 AWG 

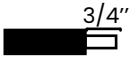
L1:
6 AWG - 250 kcmil 

L2:
6 AWG - 250 kcmil 

N:
6 AWG - 250 kcmil 

PE:
6 AWG - 2/0 AWG 

FOX Hub G2

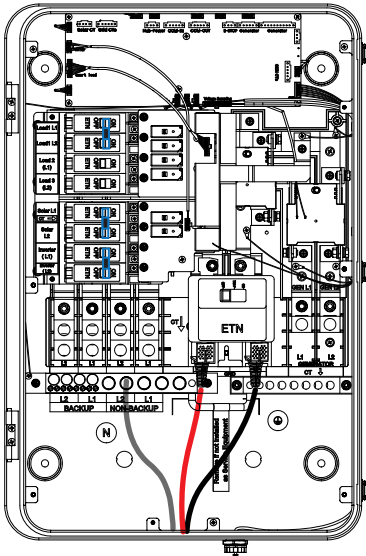

FOX Hub G2 as Service Panel

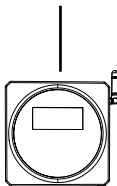

To Utility Meter

FOX Hub G2

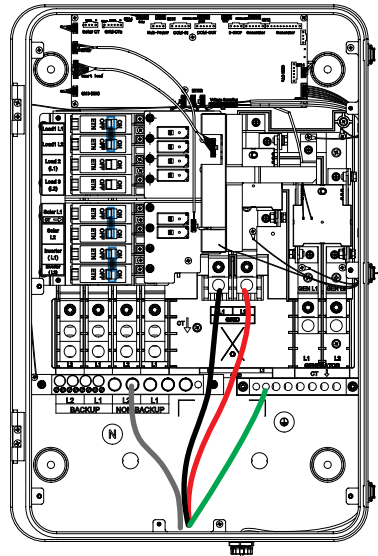

FOX Hub G2 not as Service Panel

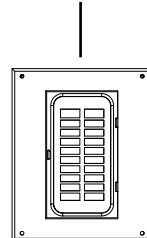

To Main Panel

5.3.7 The Existing Solar Inverter Connections to the FOX Hub G2 or main panel (Optional)

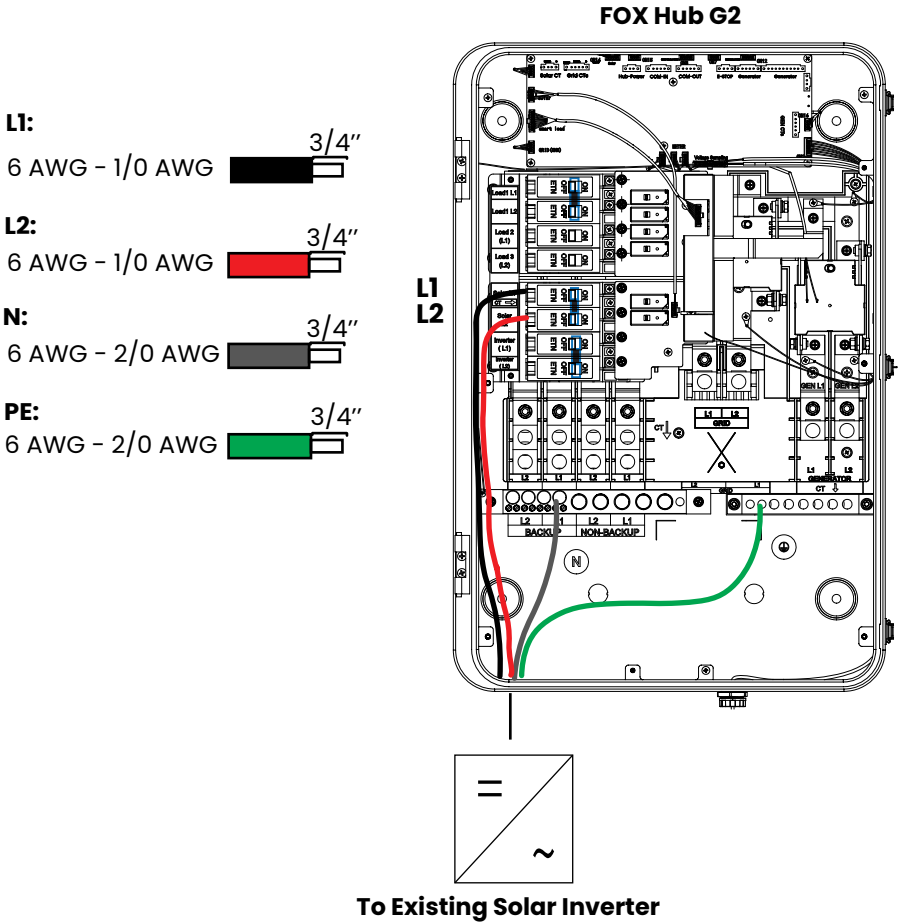

NOTE:



The conditions for connecting the existing solar inverter to the main panel are: the system has only one inverter, no generator, and the power rating of the existing solar inverter is below the FOX inverter's power rating.

5.3.8 The Smart Loads Connections to the FOX Hub G2 (Optional)

L1:
6 AWG - 1/0 AWG  3/4"

N:
6 AWG - 2/0 AWG  3/4"

L2:
6 AWG - 1/0 AWG  3/4"

PE:
6 AWG - 2/0 AWG  3/4"

FOX Hub G2

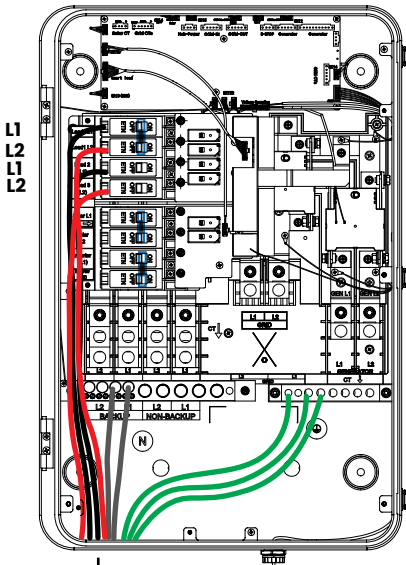

To 3 Smart Loads (240V, 120V, 120V)

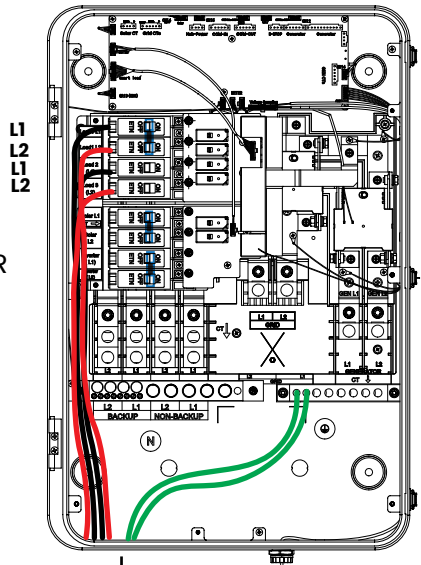

FOX Hub G2

OR

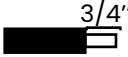
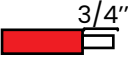

To 2 Smart Loads (240V, 240V)

5.3.9 The Standby Generator Connections to the FOX Hub G2 (Optional)

- L1:**
6 AWG - 250 kcmil  3/4"
- L2:**
6 AWG - 250 kcmil  3/4"
- N:**
6 AWG - 250 kcmil  3/4"
- PE:**
6 AWG - 2/0 AWG  3/4"

FOX Hub G2

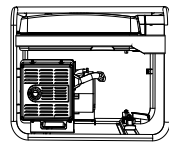
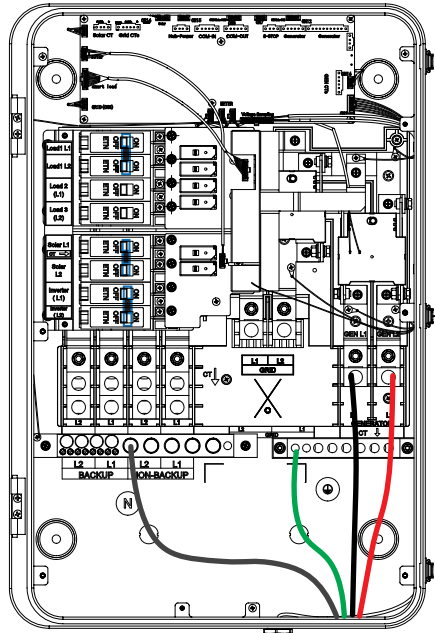

To Standby Generator

5.4 Inverter Power Cable Wiring

5.4.1 The Battery Connections to the Inverter

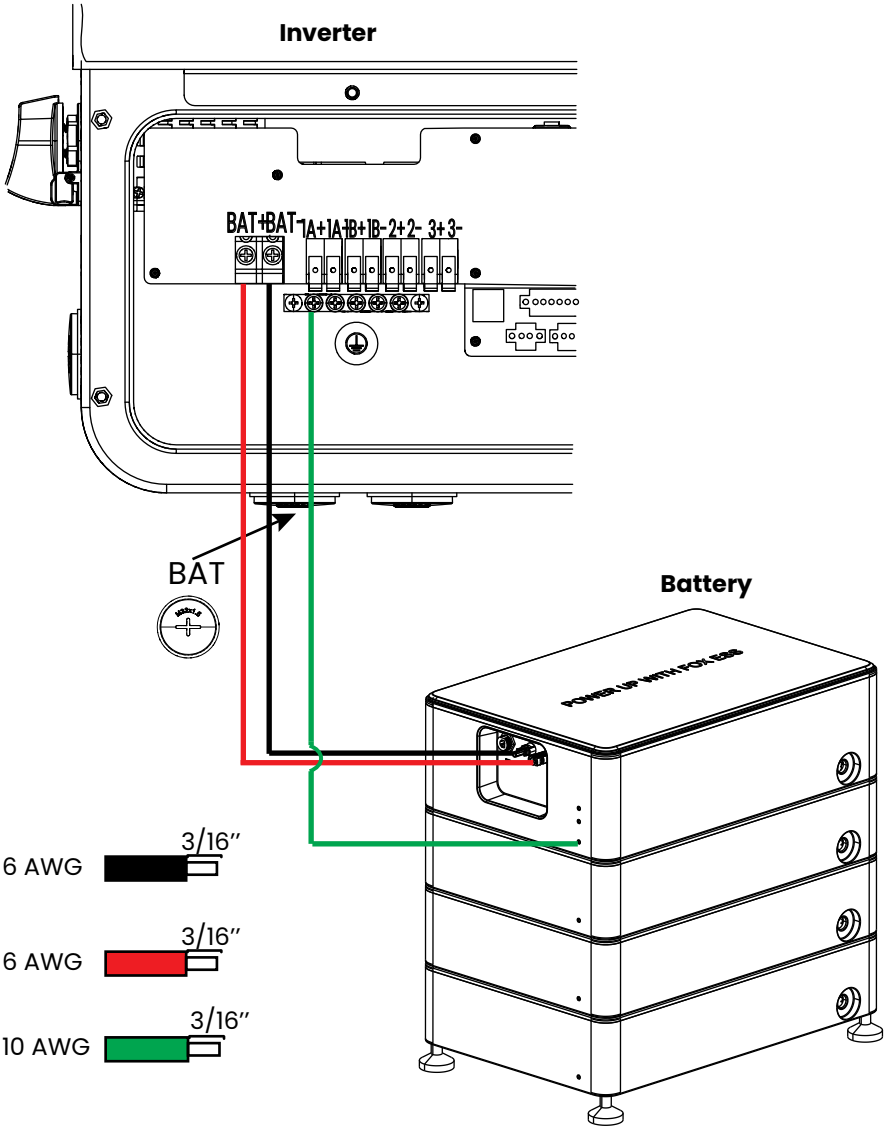

NOTE: This manual takes the ECS4000 series battery as an example. Always refer to the actual product and its quick install guide.

5.4.2 The PV Panels Connections to the Inverter

Turn off the DC switch before connection.

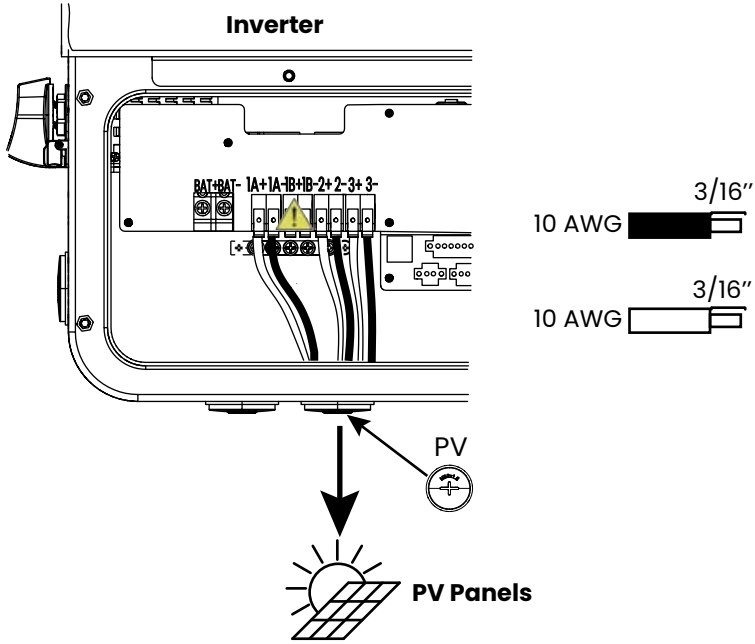

If there are ≤ 3 PV strings, 3 PV strings are preferentially connected to terminals 1A+, 1A-, 2+, 2-, 3+, 3-.

If there are 4 PV strings, the number of PV panels connected to terminals 1A+, 1A- needs to be the same as that connected to terminals 1B+, 1B-.

5.5 FOX Hub G2 Wiring (Communication & Auxiliary Power)

5.5.1 The FOX Inverter Connections to the FOX Hub G2 (1 to 4 FOX Inverters)

- | | |
|---|---|
|  16 AWG |  16 AWG |
|  24-16 AWG |  24-16 AWG |
|  24-16 AWG |  24-16 AWG |

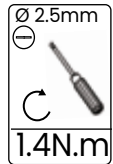

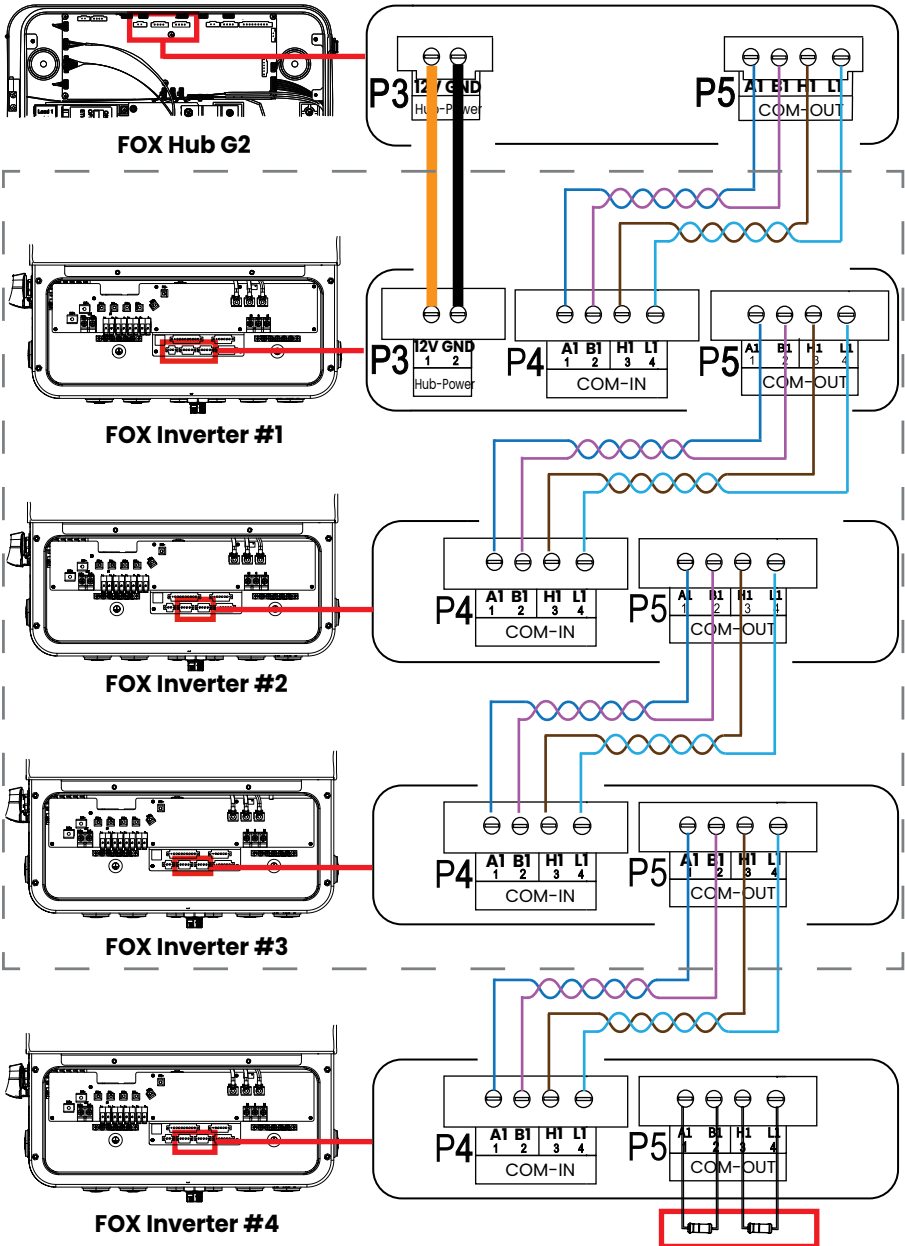

(Two resistors are in FOX Hub G2 package box)

NOTE:



- ① In the last inverter in the communication chain, plug the 4-pin P5 socket with two terminating 120Ω resistors.
- ② The twisted cables use shielded twisted pair with drain wire.
- ③ The maximum cable lengths between FOX Hub G2 and FOX Inverter #1, between FOX inverters, and between the battery and FOX inverter are 50m, 5m, and 50m, respectively .

5.5.2 The FOX Hub G2 Connections to the Standby Generator

Caution: it is essential to disconnect the DC and AC before wiring. Please be cautious.

5.5.2.1 Control Type: Utility Voltage Sense

Take Guardian series standby generator as an example.

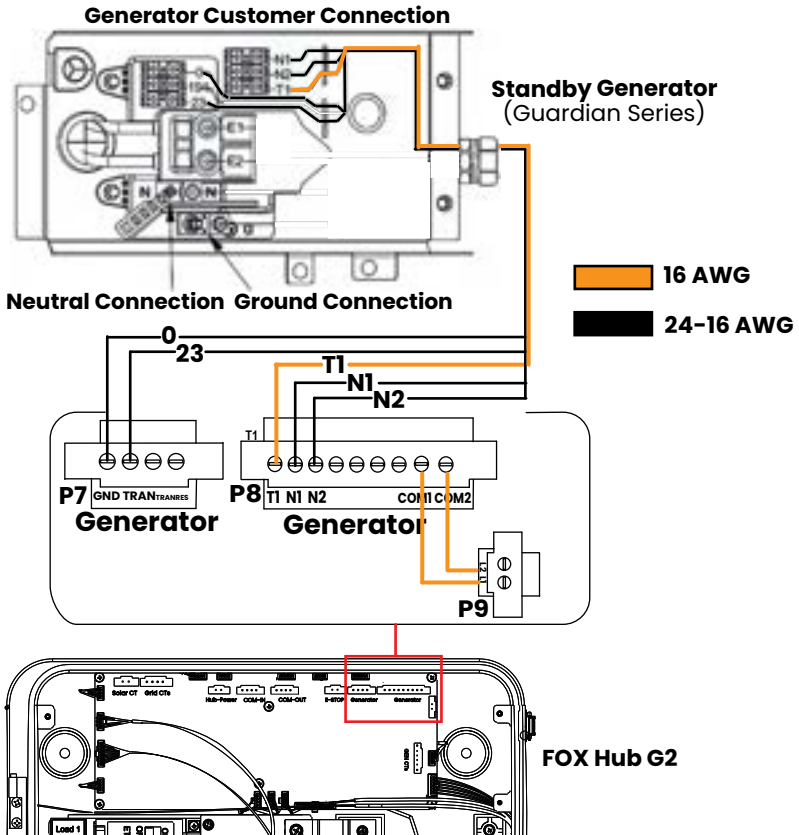

NOTE:



If the generator is connected to the FOX hub G2, the system needs to include batteries.

5.5.2.2 Control Type: Dry Contact

① Dry contact normally open generator

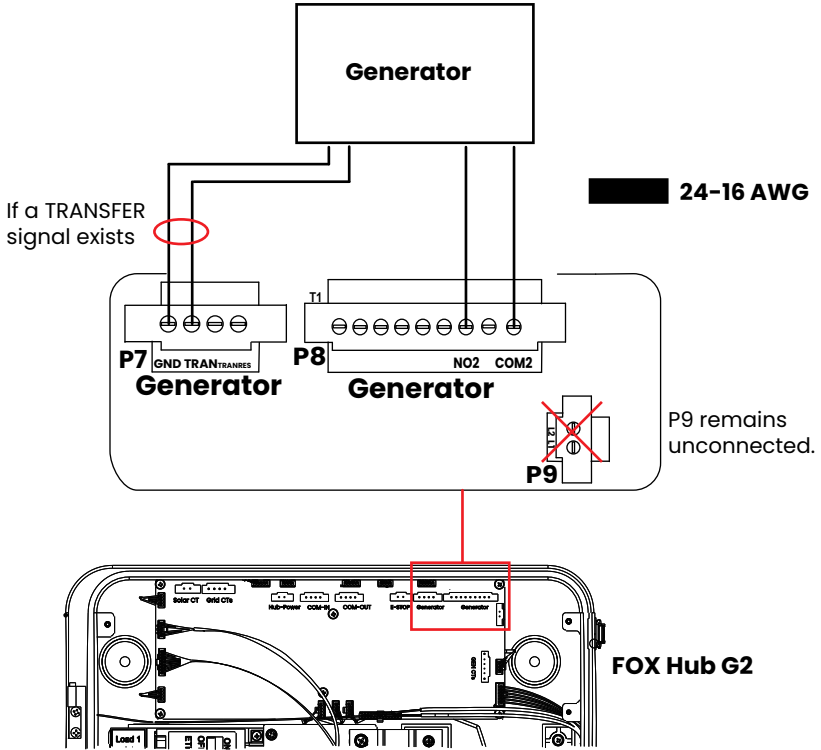

② Dry contact normally closed generator

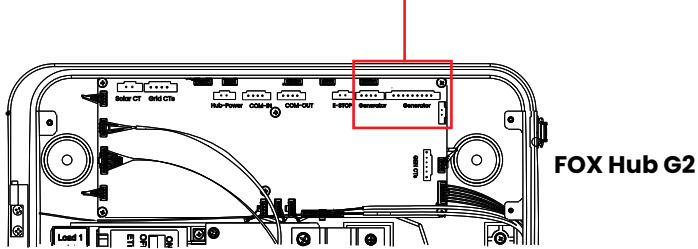
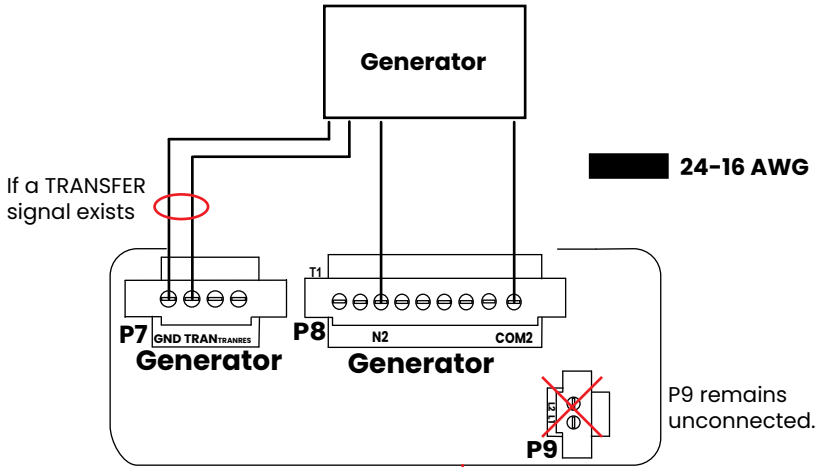

- ③ If the generator's battery needs our system to charge it,
- Providing 120 VAC

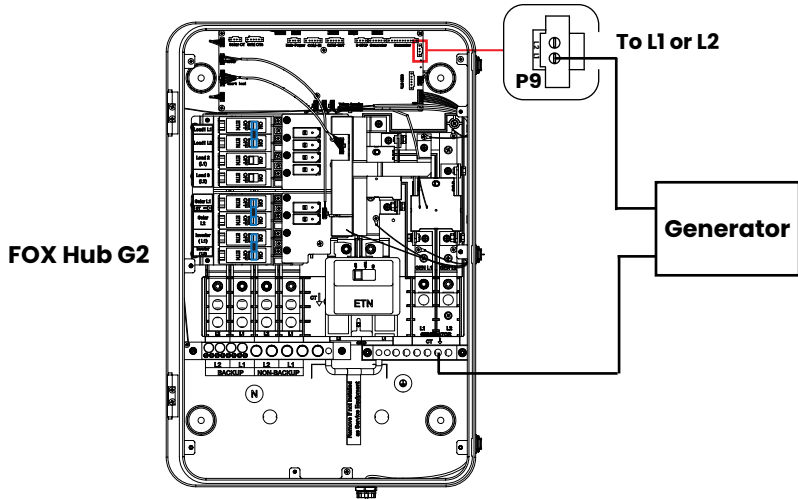

- Providing 240 VAC

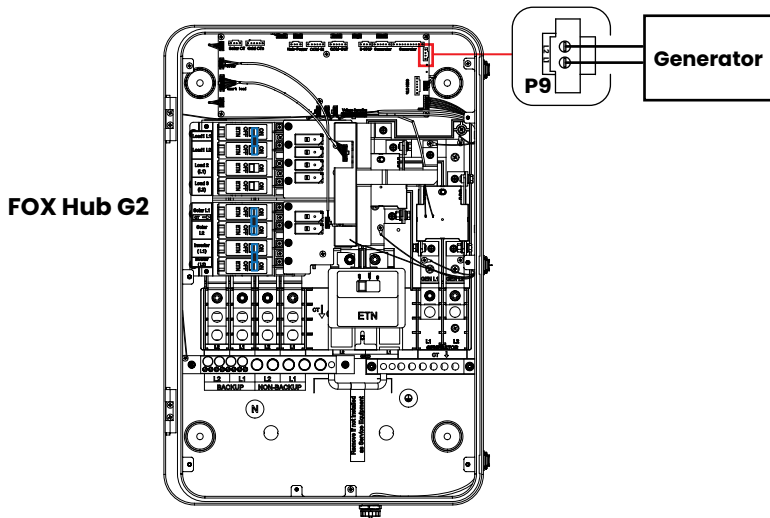

5.6 CT Wiring

- Solar CT Wiring (Only for AC Couple)

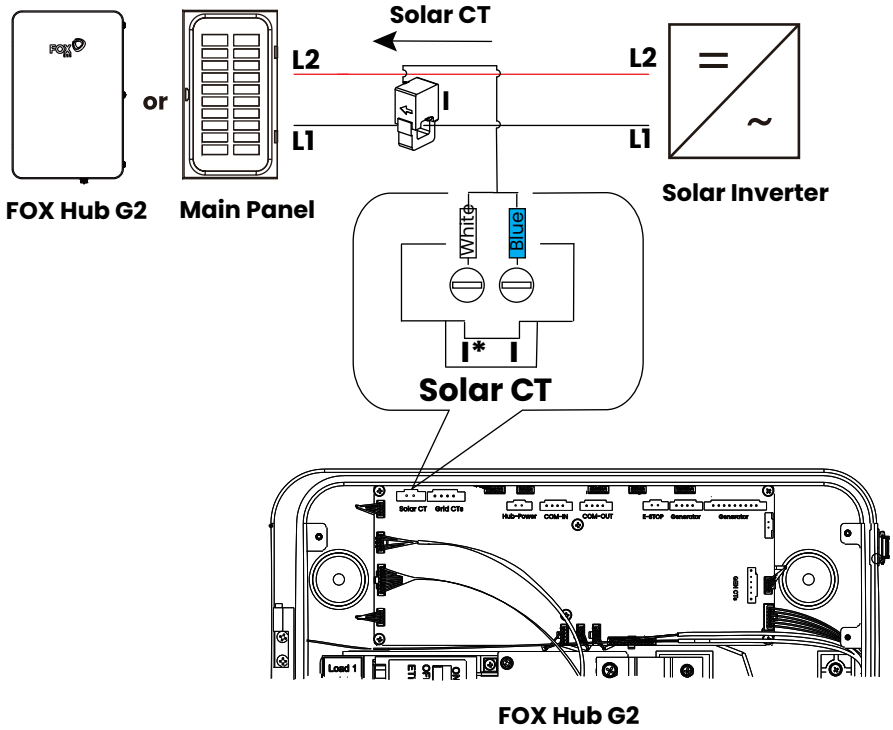

• Grid CTs Wiring

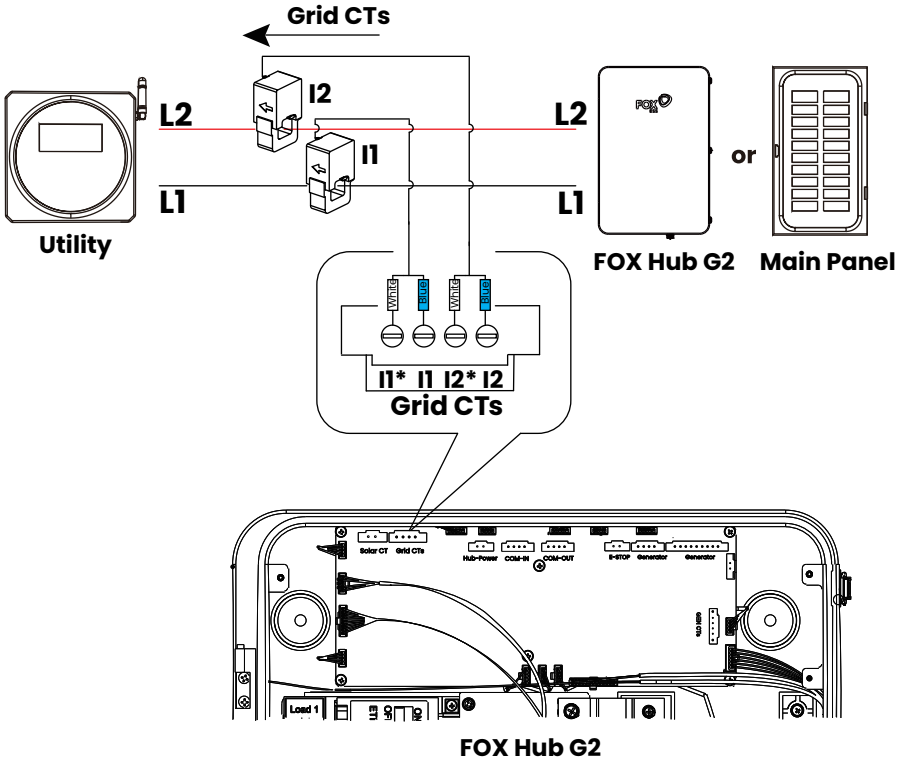

5.7 Battery Communication Wiring

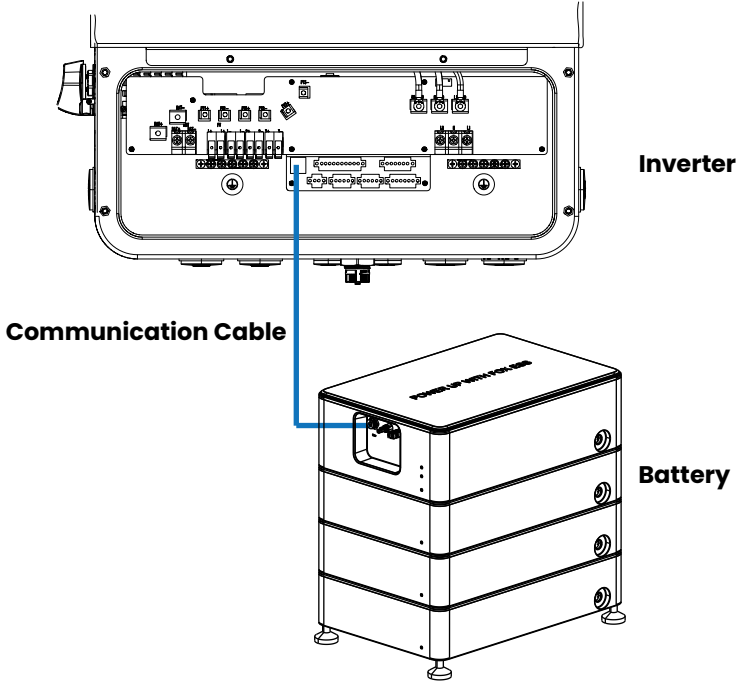

5.8 E-STOP Wiring

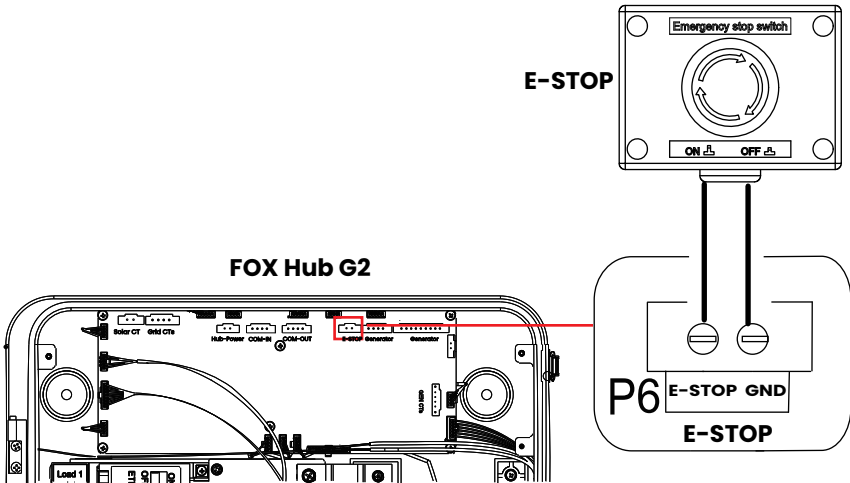

Step 1: remove the jumper on the P6 socket of the **FOX Hub G2**.

Step 2: connect the pins 1 and 2 of the P6 to the E-STOP.



WARNING:

Do not remove the jumper on the P6 socket of the **FOX inverter**.

5.9 Smart WiLAN Connection

- WiFi Installation: connect the Smart WiLAN to the **FOX Hub G2**.

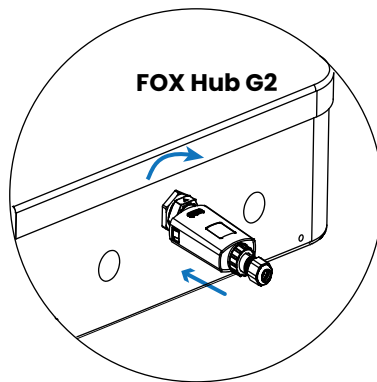

- LAN Installation: insert the network cable into the Smart WiLAN, and connect the Smart WiLAN to the **FOX Hub G2**.

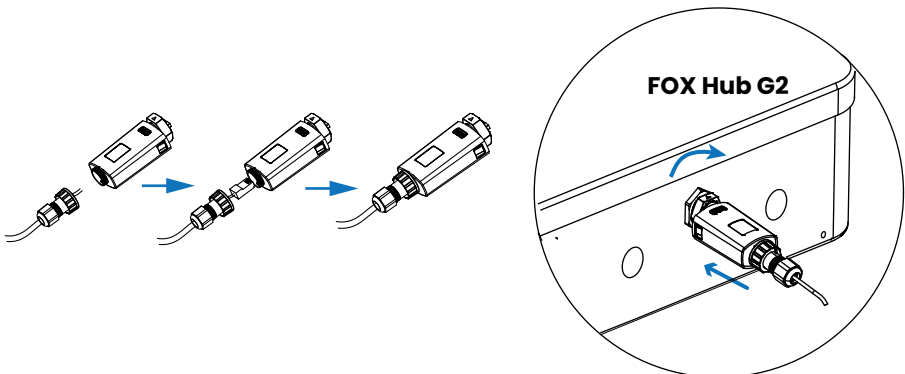

Please refer to the following steps to switch on the system.

1. Ensure all cables are connected properly.
2. Turn on the PV/DC switch on the inverter (Only for New System), and AC breakers.
3. **Battery without heating function:**
 - (Case 1) **Normal mode:** When there is PV and grid access,
 - Turn on DC switch of the battery.
 - Press "POWER" button of the battery.
 - (Case 2) **Black Start:** When there is no PV and grid access,
 - Turn on the DC switch of the battery.
 - Press the "POWER" button of the battery.
 - Press and hold the "B-Start" button within 30 seconds of the last step, releasing it after 10 seconds.

Battery with heating function:

- (Case 1) **Normal mode:** When there is PV and grid access,
 - Turn on DC switch of the battery.
 - Press and hold "POWER" button of the battery for 3 seconds, and then release.
 - (Case 2) **Black Start:** When there is no PV and grid access,
 - Turn on the DC switch of the battery.
 - Press and hold the "POWER" button of the battery for 3 seconds, and then release.
 - Press the "POWER" button for 3 times within 4 seconds (completed within 30 seconds of the last step).
4. Check if green lights on the inverter are solid on.

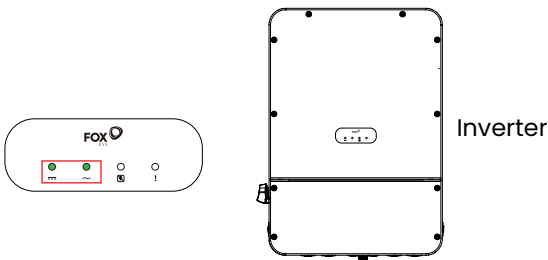

In case you need to turn off the system, please refer to the following steps:

1. Turn off the PV/DC switch, AC breakers and off-grid breaker of the FOX Hub G2.

2. **Battery without heating function:**

• Press the "POWER" button of the battery.

Battery with heating function:

• Press and hold the "POWER" button of the battery for at least 5 seconds until all Master LEDs (BMS/SOC) blink.

3. Wait 5 minutes before opening the upper cover of the inverter for repair.

7 Commissioning

Step 1: scan the QR code to download FoxCloud2.0 app and download the app.



After the app is installed, the FoxCloud2.0 icon is displayed on the home screen.



FoxCloud2.0

Step 2: Initial App Configuration (First Download Only)

- Tap “Getting Started”, select “North America”.

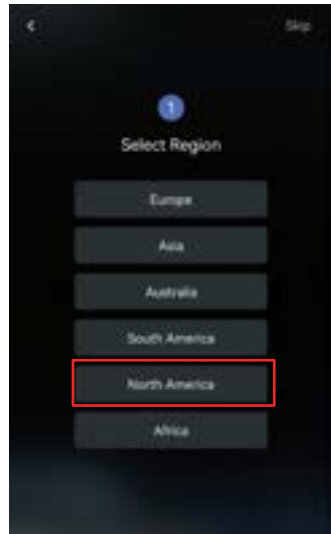

- Create an account.
For installers/distributors

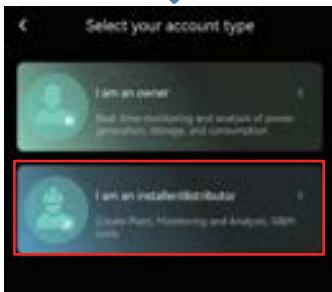
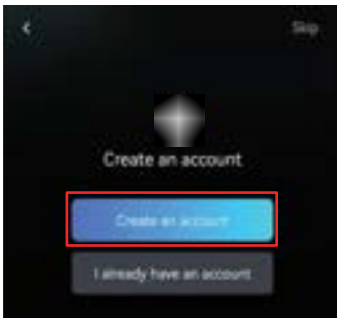

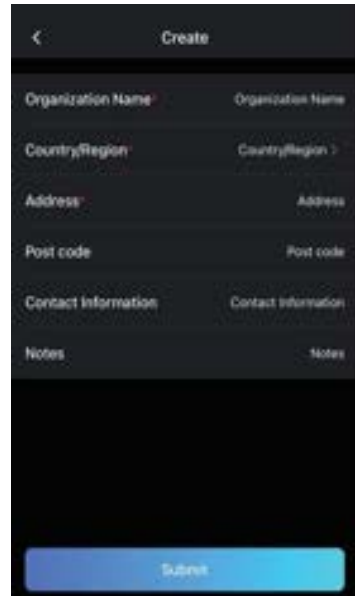

- Connect to the network. Turn on the Bluetooth of your phone in advance.

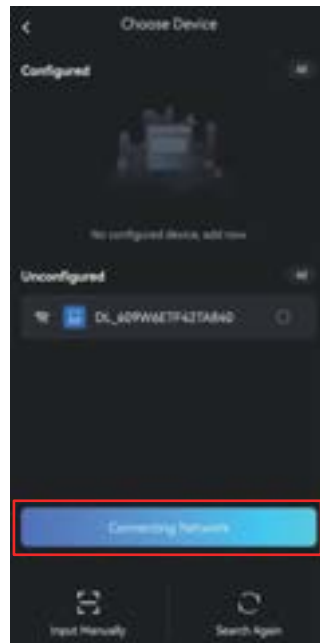
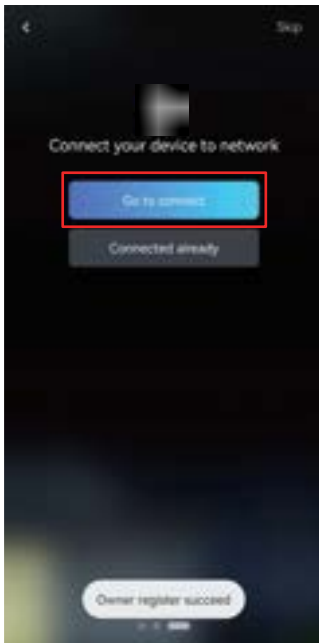

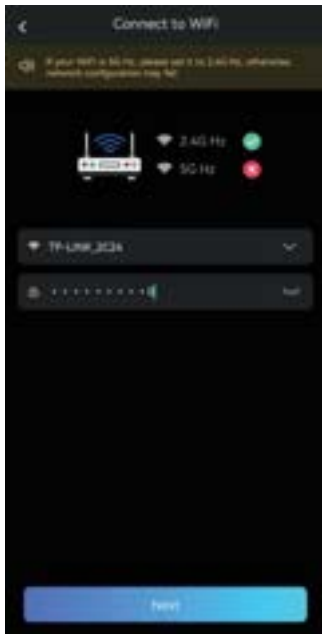

Step 3: Tap “...” at the right corner, select “**WLAN Configuration**”.

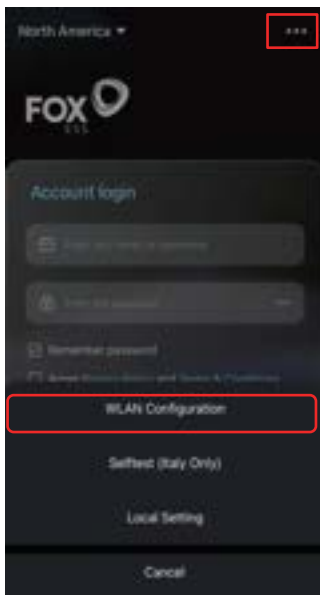

Or, manually enter the SN code on the Smart WiLAN.

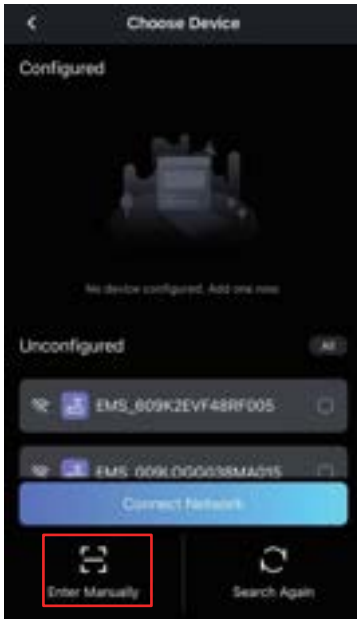

Light indication on the Smart WiLAN

Indicator	Status	Instructions
Red light	Blinking	Not connected to the server
	Solid on	Connected to the server
Green light	Blinking	Data transmission

Step 4: Sign in the installer's account. Tap **"Create a plant"**.

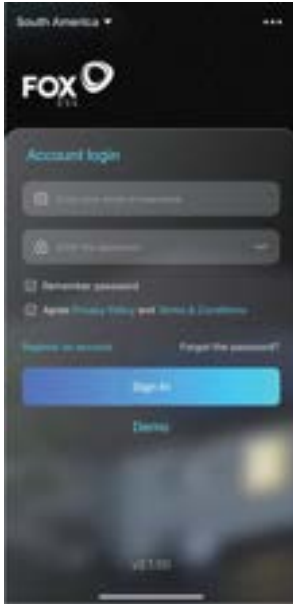

Scan the QR code on the Smart WiLAN or enter the SN code, and fill the information.



Step 5: Check system performance on “Plant” dashboard.



Step 6: Use the checklist below to make sure the necessary items are completed.

Item	Necessary or Optional	Status (✓ if completed)
1. Time Zone	Necessary	
2. Energy Mode	Necessary	
3. Zero Back-feed	Optional	
4. Service Panel Parameter	Optional (Only needed when the FOX Hub G2 is not used as a service panel)	
5. Grid Code	Optional (Only needed when selling to countries except US; Change “USA” into your own country)	
6. Existing Solar Inverter Power	Optional (Only needed in Existing System)	
7. Charge from Grid	Optional (Only needed when main breaker cannot support inverter output during full load)	

Item 1: Set up the time zone on the “Plant” dashboard.

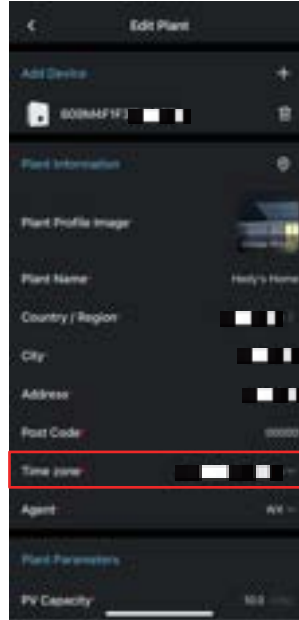

Item 2: Configure the energy management mode on the “Plant” dashboard.

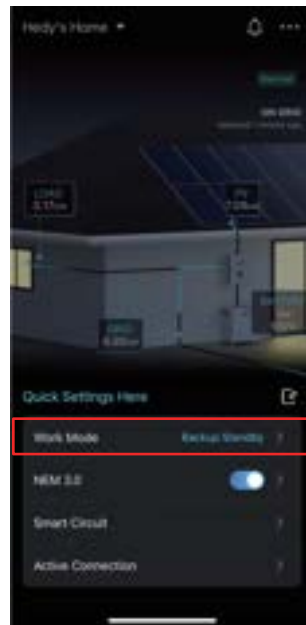

Item 3: Set the zero back-feed on the **"Device"** dashboard.

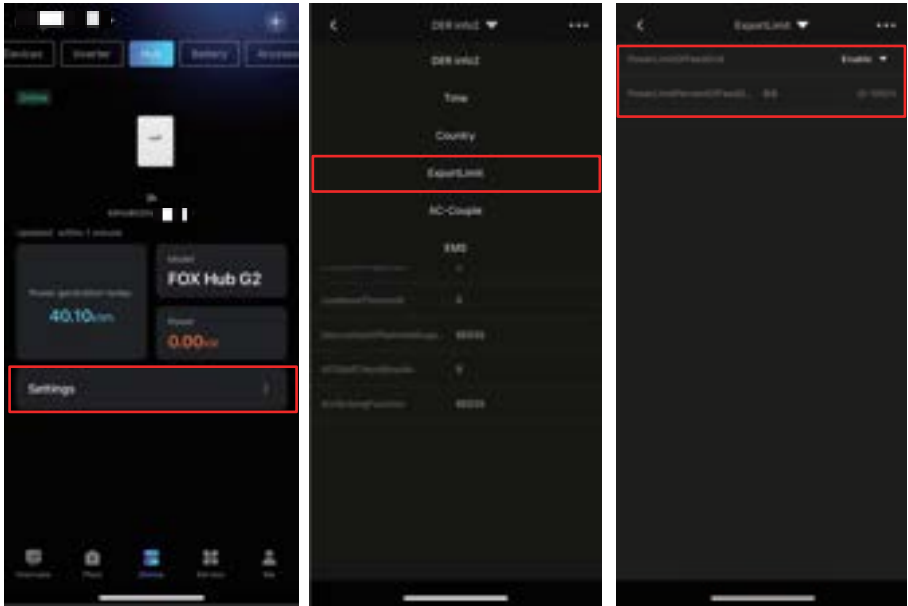

Item 4: Set service panel parameters on the **"Device"** dashboard.

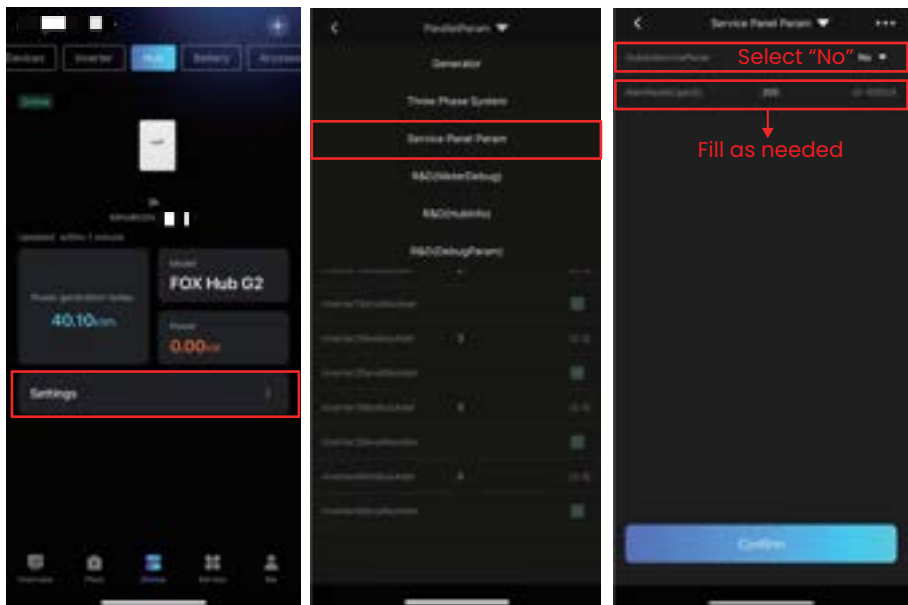

Item 5: Set the grid code on the **"Device"** dashboard.

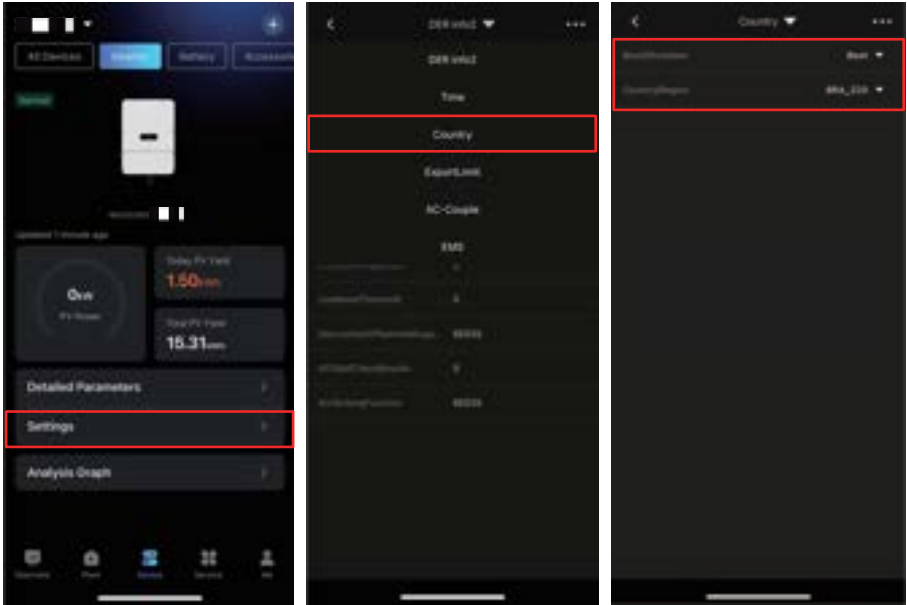

Item 6: Set the existing solar inverter power on the **"Device"** dashboard.

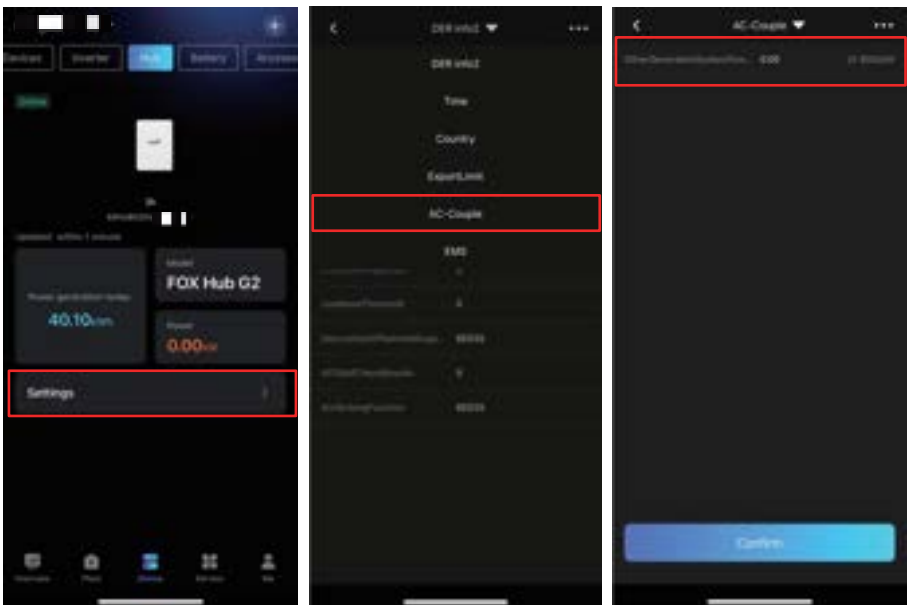

Item 7: Set the the charge by grid value on the “**Device**” dashboard.

